

### Input Specifications

Input voltage range		85- 264VAC, 120- 370VDC
Input frequency		47- 63Hz
Input current	PPM05 PPM10 PPM15 PPM20 PPM25	110VAC 230VAC 120mA , typ. 70mA , typ. 230mA , typ. 120mA , typ. 250mA , typ. 140mA , typ. 330mA , typ. 180mA , typ. 420mA , typ. 230mA , typ.
Inrush current	PPM05 PPM10 PPM15 PPM20/PPM25	110VAC 230VAC 10A, typ. 20A, typ. 10A, typ. 20A, typ. 10A, typ. 20A, typ. 16A, typ. 30A, typ.
External input fuse(recommended)	PPM05 PPM10/PPM15 PPM20/PPM25	1A/250V slow blow 2A/250V slow blow 3.15A/250V slow blow

### Output Specifications

Voltage set accuracy		±2%(main out)
Input variation		±0.5% (main output) ±1.5% (supplement output)
Load variation (10-100%)	Single output models	±1%
Ripple& noise(p-p)	20MHz Bandwidth	≤100mV
Short circuit protection		Continuous, and auto resume
Over current protection		≥110% IO
Over output voltage protection	3.3 / 5VDC models 9VDC model 12 / 15VDC models 24VDC model 48VDC model	≤6.5VDC ≤12VDC ≤20VDC ≤30VDC ≤60VDC

### General Specifications

Temperature ranges	Operating : Power derating above 55 °C: Storage: Case temperature:	-25 °C to +70 °C 3.75%/°C (2.25%/°C PPM20-D-05ELF < 50 °) -25 °C to +105 °C +90 °C max
Weight	PPM05, PPM10, PPM15, PPM20/25	~50g, ~70g, ~80g, ~120g
Hold-up time	(Vin=230VAC)	80ms(typ.)
Humidity (non condensing)		85%(max)
Temperature coefficient		0.02% /°C
Switching frequency		150kHz max
Efficiency		See table
I/O-isolation voltage		3000VAC/1Min
Leakage current		0.3mA RMS typ. 230VAC/50Hz
Case material		UL 94V-0 rated
Install		PCB
MTBF		>200,000h @25 °C
RoHS compliant		Soldering 260 °C / max. 10 sec.

**Examples of Partnumbers/Modelcode**

PART NO.	Power (Watt)	INPUT CURRENT (mA, typ.) 110VAC / 230VAC	OUTPUT (Volt)	RIPPLE AND NOISE (typ..)	EFFICIENCY (% min.)
PPM05-A-3.3ELF	4	120 / 70	3.3V / 1250mA	50mV	70
PPM05-A-05ELF	5	120 / 70	5V / 1000mA	50mV	75
PPM05-A-09ELF	5	120 / 70	9V / 550mA	50mV	77
PPM05-A-12ELF	5	120 / 70	12V / 420mA	50mV	79
PPM05-A-15ELF	5	120 / 70	15V / 330mA	50mV	80
PPM05-A-24ELF	5	120 / 70	24V / 230mA	50mV	82
PPM10-B-3.3ELF	6.6	230 / 120	3.3V / 2000mA	50mV	70
PPM10-B-05ELF	10	230 / 120	5V / 2000mA	50mV	76
PPM10-B-09ELF	10	230 / 120	9V / 1100mA	50mV	78
PPM10-B-12ELF	10	230 / 120	12V / 900mA	50mV	80
PPM10-B-15ELF	10	230 / 120	15V / 700mA	50mV	81
PPM10-B-24ELF	10	230 / 120	24V / 450mA	50mV	82
PPM15-C-3.3ELF	9.9	250 / 140	3.3V / 3000mA	50mV	73
PPM15-C-05ELF	15	250 / 140	5V / 2800mA	50mV	76
PPM15-C-09ELF	15	250 / 140	9V / 1600mA	50mV	78
PPM15-C-12ELF	15	250 / 140	12V / 1250mA	50mV	80
PPM15-C-15ELF	15	250 / 140	15V / 1000mA	50mV	80
PPM15-C-24ELF	15	250 / 140	24V / 625mA	50mV	84
PPM15-C-48ELF	15	250 / 140	48V / 320mA	50mV	85
PPM20-D-3.3ELF	20	330 / 180	3.3V / 4100mA	50mV	73
PPM20-D-05ELF	20	330 / 180	5V / 3500mA	50mV	75
PPM20-D-12ELF	20	330 / 180	12V / 1600mA	50mV	81
PPM20-D-15ELF	20	330 / 180	15V / 1300mA	50mV	83
PPM20-D-24ELF	20	330 / 180	24V / 850mA	50mV	85
PPM25-D-05ELF	25	420 / 230	5V / 4100mA	50mV	74
PPM25-D-12ELF	25	420 / 230	12V / 2100mA	50mV	82
PPM25-D-15ELF	25	420 / 230	15V / 1600mA	50mV	83
PPM25-D-24ELF	25	420 / 230	24V / 1100mA	50mV	85
PPM25-D-48ELF	25	420 / 230	48V / 500mA	50mV	87

Other specifications please enquire.

**Dimensions / Pinning**

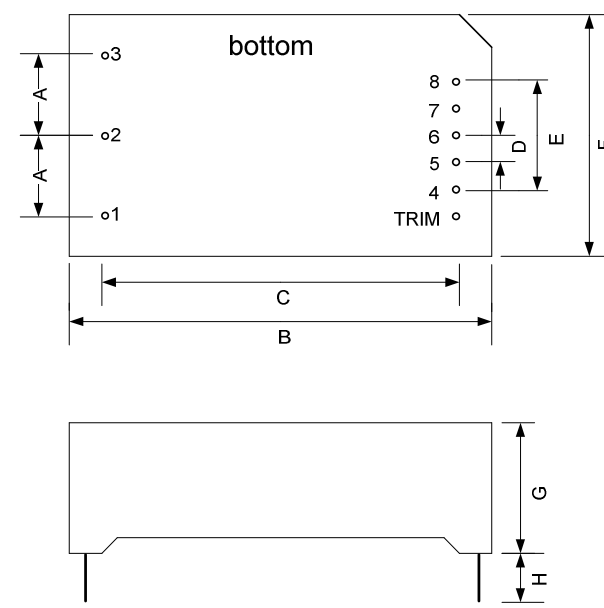

PINNING PPMxx-x-xxELF	
#	Single Output
1	Ground*
2	AC (N)
3	AC (L)
4	- V Output
5	Omitted
6	Omitted
7	Omitted
8	+ V Output
TRIM	TRIM**

\* No G. on PPM15-x  
\*\* Only for PPM20/25-x

**NOTE:**  
Unit: mm  
Pin section: 1.00mm  
Pin tolerances: +/- 0.1mm  
General tolerances: +/- 0.5mm

No.	PPMxx-A	No.	PPMxx-B	No.	PPMxx-C	No.	PPMxx-D
A	12.5	A	17.5	A	17.5	A	20.0
B	48.5	B	55.0	B	62.0	B	70.0
C	40.5	C	47.0	C	54.0	C	62.0
D	4.0	D	5.0	D	5.0	D	5.75
E	16.0	E	20.0	E	20.0	E	23.0
F	36.0	F	45.0	F	45.0	F	48.0
G	20.5	G	20.5	G	22.5	G	23.5
H	min. 6.0	H	min. 6.0	H	min. 6.0	H	min. 6.0

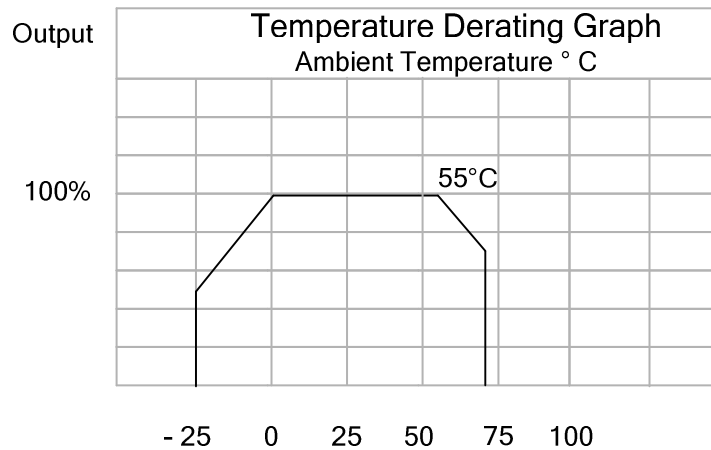

**App Notes**

Remarks :

1. Ripple and Noise were measured by the method of parallel lines;
2. Unless otherwise specified, all specifications above are measured at rated input voltage and rated output load, TA=25°C, humidity < 75%;
3. All specifications stated in this datasheet are subject to the above listed model only. For specifications of non-standard model, please contact our technical support team.

**Parallel Lines Measure**

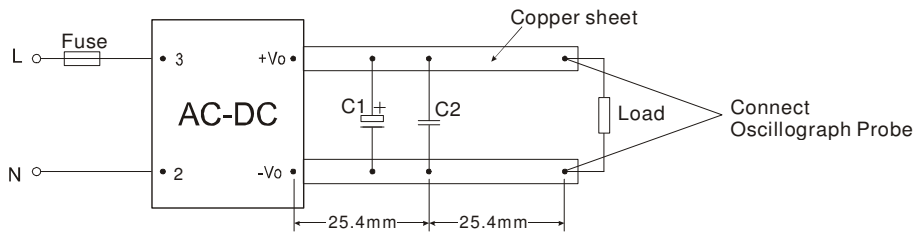

**Typical Applications PPM-Series**

PPMxx-x-xxELF (single Output)

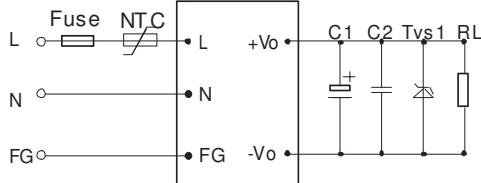

**Remarks**

1. Output filtering capacitor C5, C3 and C1 are electrolytic capacitor. It is recommended to use high frequency and low resistance electrolytic capacitor. For capacitance and current of the capacitor please refer to suppliers' specifications. Voltage derating of capacitor should be 80% or above. C2, C4 and C6 eliminate high frequency noise. TVS is a recommended component to protect post-circuits (when converter fails).
2. External input NTC is recommended to use 5D-9 (Only PPM10 model and PPM15 model)

External Typical Value

Partnumber	C1	Partnumber	C1
PPM05-A-3.3ELF	330	PPM15-C-3.3ELF	680
PPM05-A-05ELF	330	PPM15-C-05ELF	680
PPM05-A-09ELF	120	PPM15-C-09ELF	470
PPM05-A-12ELF	120	PPM15-C-12ELF	220
PPM05-A-15ELF	68	PPM15-C-15ELF	220
PPM05-A-24ELF	68	PPM15-C-24ELF	68
		PPM15-C-48ELF	33
PPM10-B-3.3ELF	470		
PPM10-B-05ELF	330	PPM20-D-3.3ELF	330
PPM10-B-09ELF	120	PPM20-D-05ELF	330
PPM10-B-12ELF	120	PPM20-D-12ELF	220
PPM10-B-15ELF	120	PPM20-D-15ELF	220
PPM10-B-24ELF	68	PPM20-D-24ELF	220
		PPM25-D-12ELF	330
		PPM25-D-15ELF	330
		PPM25-D-24ELF	120
		PPM25-D-48ELF	68

**TRIM (only PPM20/25-D-xxELF)**

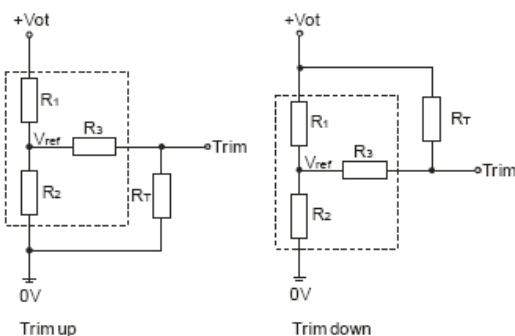

	3.3V	5V	12V	15V	24V	48V
R1(KΩ)	2	3.3	3.83	7.5	8.66	1.2
R2(KΩ)	1.2	3.3	1	1.5	1	22
R3(KΩ)	1	1	1	1	1	1.2
Vref(V)	1.24	2.5	2.5	2.5	2.5	2.5
Vot(V)	Output voltage of Trim, variation ≤ ±10%					

$$\text{up: } R_T = \frac{aR_2}{R_2 - a} - R_3 \quad a = \frac{V_{ref}}{V_{ot} - V_{ref}} \cdot R_1$$

$$\text{down: } R_T = \frac{aR_1}{R_1 - a} - R_3 \quad a = \frac{V_{ot} - V_{ref}}{V_{ref}} \cdot R_2$$

Note: Value for R1, R2, R3, and Vref refer to the following table.

R<sub>T</sub>: Resistance of Trim

a: User-defined parameter, no actual meanings.